

DESIGN NOTES

5V High Current Step-Down Switchers – Design Note 59

Ron Vinsant and Milton Wilcox

Low Cost High Efficiency (80%), High Power Density DC-to-DC Converter

The LT1241 current mode PWM control IC can be used to make a simple high frequency step-down converter. This converter also has low manufacturing costs due to simple magnetic components. This circuit exhibits a wide input range of 30V to 60V while maintaining its 12A 5V output. It has short circuit protection and uses minimal PC board area due to its 300kHz switching frequency.

Figure 1 shows the LT1241 being used to drive the switching transistor Q1 through a ferrite pulse transformer T2. This transformer is built on a high μ material resulting in an 11 turn bifilar wound toroid that is only 0.15 inches in diameter and can be surface mounted. T1 acts as a current sense transformer whose volt • second

balance is assured by the duty cycle limit of 50% inherent in the LT1241. The output inductor (L1) is made of Magnetics Kool-Mu material and is only 0.7 inches in diameter.

Short circuit protection is provided through bootstrap operation of the LT1241. If the output is shorted the LT1241 limits its pulse width to ≤ 250 ns. Because there is not enough current supplied to make the aux winding on the output inductor 15V, the LT1241 stops operation. It will then try to start by C11 charging through R4. If the output is still shorted it will stop again. Thus in a short, the circuit starts and stops, protecting itself from overload.

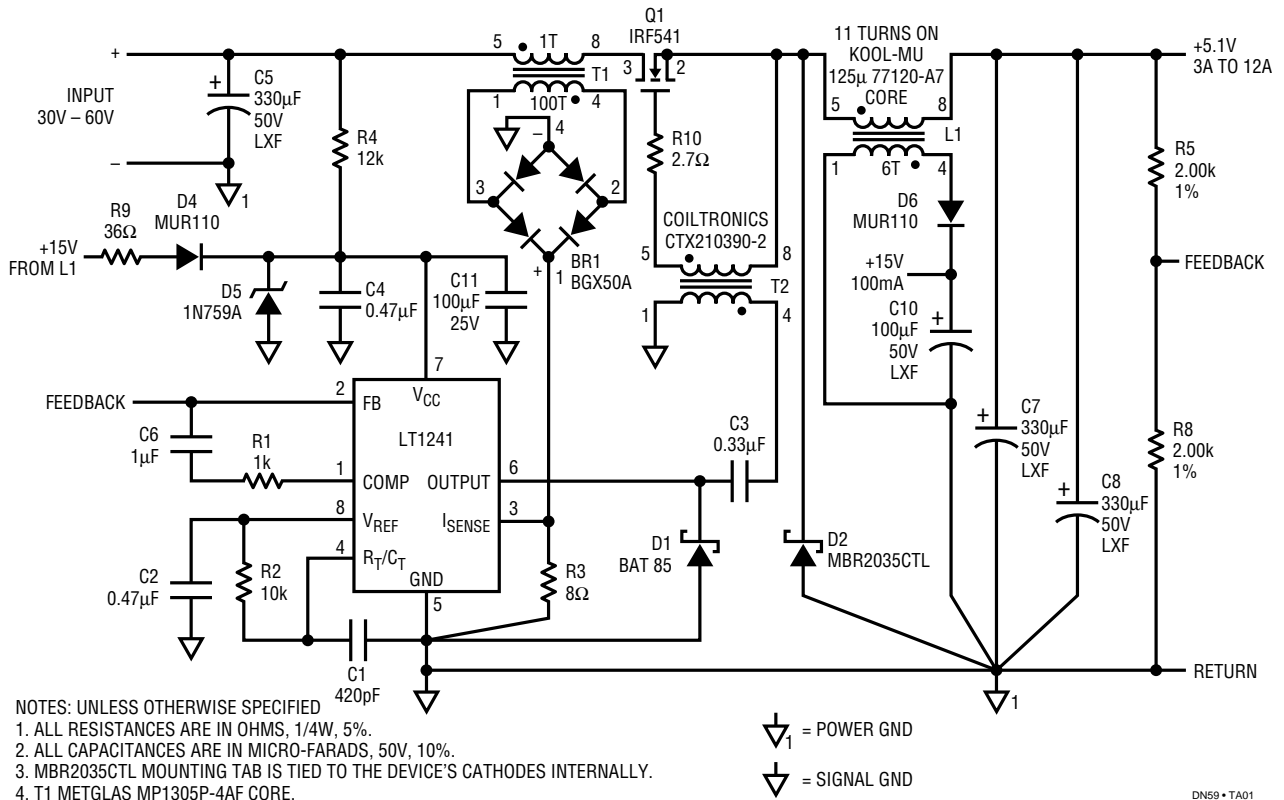

Figure 1.

Synchronous Switching Eliminates Heatsinks in a 50W DC-to-DC Converter

The new LT1158 half bridge N-Channel power MOSFET driver makes an ideal synchronous switch driver to improve the efficiency of step-down (buck) switching regulators. The diode losses in a conventional step-down regulator become increasingly significant as V_{IN} is increased. By replacing the high-current Schottky diode with a synchronously-switched power MOSFET, efficiencies well over 90% can be realized (see Figure 2).

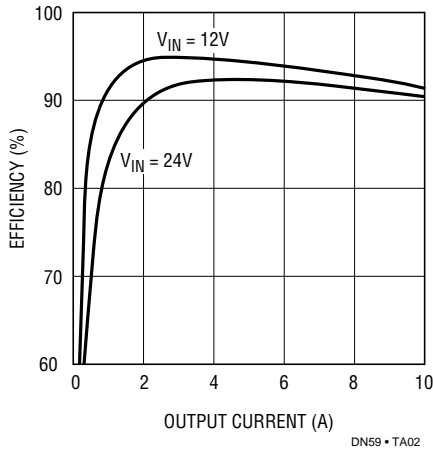

Figure 2. Operating Efficiency for Figure 3 Circuit

In the Figure 3 circuit an LT3525 provides a voltage mode PWM to drive the LT1158 input pin. The LT1158

drives (2) 28mΩ power MOSFETs for each switch, reducing individual device dissipation to 0.7W worst case. This eliminates the need for heatsinks for operation up to 10A at a temperature of 50°C ambient. The inductor and current shunt losses for the Figure 3 circuit are 1.2W and 0.7W respectively at 10A.

An additional loss potentially larger than those already mentioned results from the gate charge being delivered to multiple large MOSFETs at the switching frequency. This driver loss can only be controlled by running the oscillator at as low a frequency as practical — in the case of the Figure 3 circuit, 25kHz. A very low ESR (<20mΩ) output capacitor is used to limit output ripple to less than 50mVp-p with 2.5Ap-p ripple current.

The LT1158 also provides current limit for DC-to-DC converter applications. When the voltage across R_S exceeds 110mV, the LT1158 fault pin conducts, and assumes control of the PWM duty cycle. This provides true current mode short circuit protection with soft recovery. The Figure 3 regulator current limit is set at 15A which raises the dissipation in each bottom MOSFET to 1.7W during a short. Therefore 30°C/W heatsinking must be added for the bottom side MOSFETs if continuous short circuit operation is required. Care should also be taken when routing the sense+ and sense- leads to prevent coupling from the inductor.

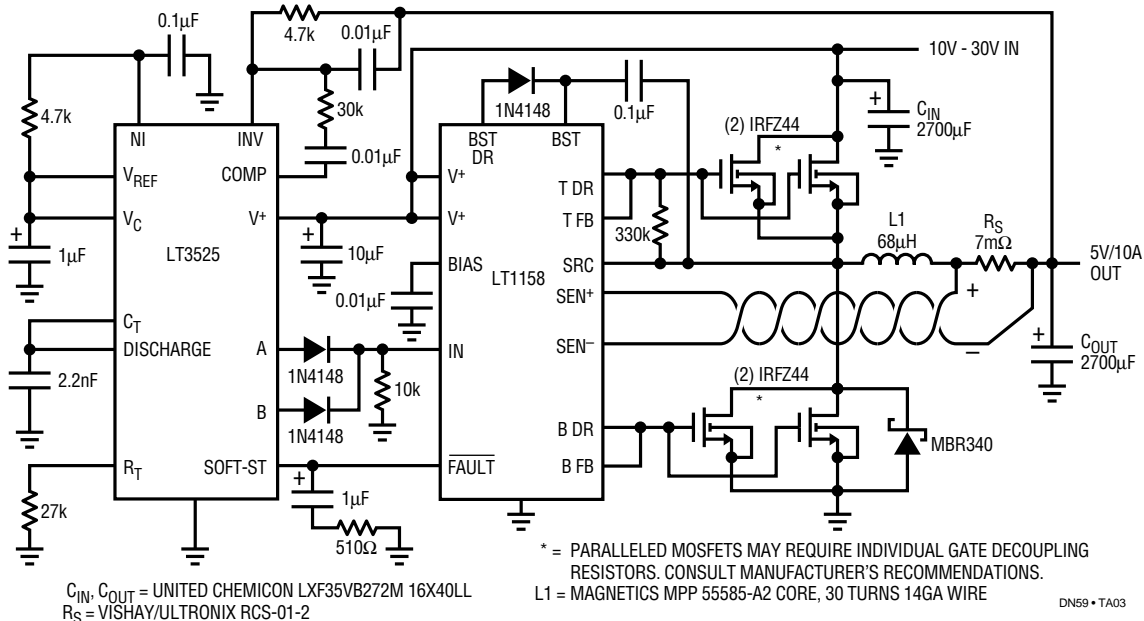

Figure 3. High Efficiency 50W DC-to-DC Converter

For literature on our Switching Regulators, call (800) 637-5545. For applications help, call (408) 432-1900, Ext. 456